



ARRL Periodicals Archive – Search Results

A membership benefit of ARRL and the ARRL Technical Information Service

ARRL Members: You may print a copy for personal use. Any other use of the information requires permission (see Copyright/Reprint Notice below).

Need a higher quality reprint or scan? Some of the scans contained within the periodical archive were produced with older imaging technology. If you require a higher quality reprint or scan, please contact the ARRL Technical Information Service for assistance. Photocopies are \$3 for ARRL members, \$5 for nonmembers. For members, TIS can send the photocopies immediately and include an invoice. Nonmembers must prepay. Details are available at www.arrl.org/tis or email photocopy@arrl.org.

QST on CD-ROM: Annual CD-ROMs are available for recent publication years. For details and ordering information, visit www.arrl.org/qst.

Non-Members: Get access to the ARRL Periodicals Archive when you join ARRL today at www.arrl.org/join. For a complete list of membership benefits, visit www.arrl.org/benefits.

Copyright/Reprint Notice

In general, all ARRL content is copyrighted. ARRL articles, pages, or documents--printed and online--are not in the public domain. Therefore, they may not be freely distributed or copied. Additionally, no part of this document may be copied, sold to third parties, or otherwise commercially exploited without the explicit prior written consent of ARRL. You cannot post this document to a Web site or otherwise distribute it to others through any electronic medium.

For permission to quote or reprint material from ARRL, send a request including the issue date, a description of the material requested, and a description of where you intend to use the reprinted material to the ARRL Editorial & Production Department: permission@arrl.org.

QST Issue: Jan 1976

Title: Accu-Keyer for QRPP Operation

Author: Gene Hinkle, WA5KPG

[Click Here to Report a Problem with this File](#)



2010 ARRL Periodicals on CD-ROM

ARRL's popular journals are available on a compact, fully-searchable CD-ROM. Every word and photo published throughout 2010 is included!

- **QST** The official membership journal of ARRL
- **NCJ** National Contest Journal
- **QEX** Forum for Communications Experimenters

SEARCH the full text of every article by entering titles, call signs, names—almost any word. **SEE** every word, photo (including color images), drawing and table in technical and general-interest features, columns and product reviews, plus all advertisements. **PRINT** what you see, or copy it into other applications.

System Requirements: Microsoft Windows™ and Macintosh systems, using the industry standard Adobe® Acrobat® Reader® software. The Acrobat Reader is a free download at www.adobe.com.

2010 ARRL Periodicals on CD-ROM

ARRL Order No. 2001

Only \$24.95*

*plus shipping and handling

Additional sets available:

2009 Ed., ARRL Order No. 1486, \$24.95
 2008 Ed., ARRL Order No. 9406, \$24.95
 2007 Ed., ARRL Order No. 1204, \$19.95
 2006 Ed., ARRL Order No. 9841, \$19.95
 2005 Ed., ARRL Order No. 9574, \$19.95
 2004 Ed., ARRL Order No. 9396, \$19.95
 2003 Ed., ARRL Order No. 9124, \$19.95
 2002 Ed., ARRL Order No. 8802, \$19.95
 2001 Ed., ARRL Order No. 8632, \$19.95



ARRL The national association for AMATEUR RADIO™

SHOP DIRECT or call for a dealer near you.
 ONLINE WWW.ARRL.ORG/SHOP
 ORDER TOLL-FREE 888/277-5289 (US)

An Accu-Keyer for QRP_p Operation

CMOS integrated circuits offer the QRP_p operator a means for having such conveniences as this adaptation of the WB4VVF Accu-Keyer.

By Gene Hinkle,* WA5KPG

When WB4VVF first described his Accu-Keyer in August, 1973, it seemed that this was the ultimate in keyer design.¹ The Accu-Keyer is an electronic keyer incorporating dot and dash memories and, available at the flick of a switch, automatic word spacing. What possible improvement could be made to a keyer that has been constructed by literally thousands of builders? Probably

the only drawback of the design is the use of power-consuming TTL digital integrated circuits which are not compatible with QRP_p operation. However with the proper part substitutions, a keyer can be built which only consumes 25 microwatts during standby! The secret to the new design is to use CMOS integrated circuits in place of the TTL circuits. CMOS circuits are inherently low power-drain devices and are now appearing on the surplus market at a price within the reach of most amateurs. CMOS ICs which have direct pin-for-pin compatibility with the TTL circuits al-

low the use of the printed circuit board offered.² The clock generator circuit is redesigned so that it has a very low standby current consumption. Fig. 1 shows the new values used in the clock circuit. Note that the number of parts and their placement are the same as those used in the original design. Thus, the original printed circuit board does not have to be modified to incorporate this design. The clock generator is the major power consumer during standby. This circuit only requires a few microamperes. The exact power consumption will vary as a function of the setting of the speed adjustment potentiometer R7.

The original Accu-Keyer circuit board left several pins floating (open circuited) on several chips. Pin 4 of U4 should be connected to pin 14, U4. Likewise, pin 4 of U5 should be connected to pin 14, U5. This is because CMOS *must* have all input pins terminated with either a 1 or 0 logic level. Otherwise, the CMOS's open inputs will cause the device to behave in a linear mode, causing high power consumption and erratic operation. The following pins should be terminated with a 10-k Ω resistor to pin 14 of any IC: (1) the dot input, (2) the dash input, (3) the automatic-space input, and (4) the tune input. These four resistors should be placed on the back of the printed circuit board and soldered directly to the pin tabs.

*1109 Rutland, No. 270, Austin, TX 78758.

¹ Garrett, "The WB4VVF Accu-Keyer," *QST*, August, 1973.

² Predrilled printed circuit boards are available for \$3.50 from Jim Garrett, 126 W. Buchanan Ave., Orlando, FL 32809.



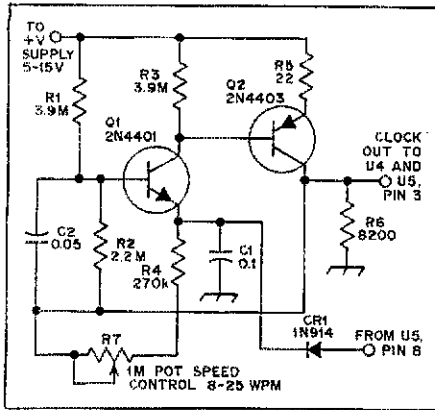
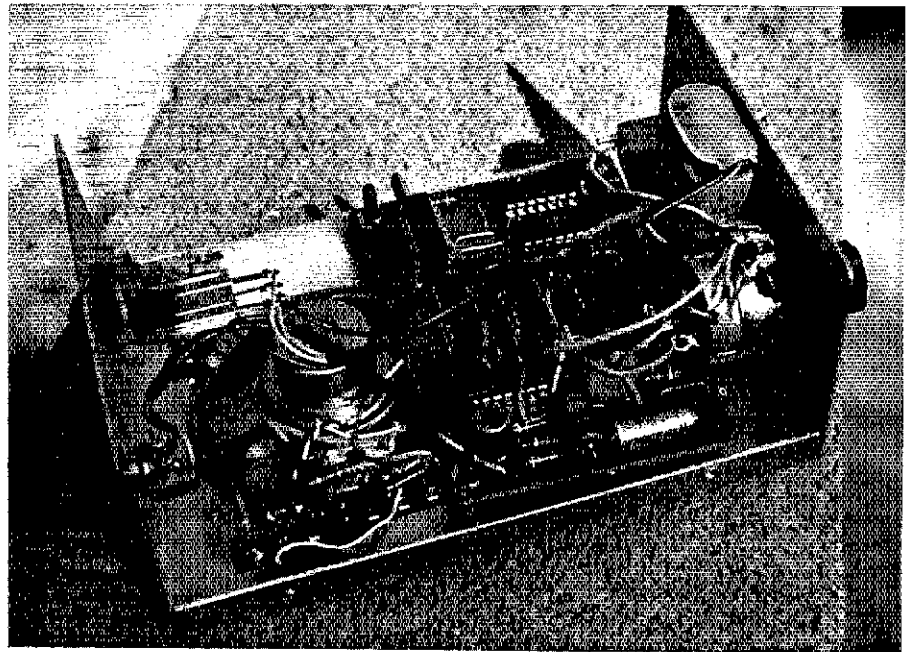

Fig. 1 — Schematic diagram of the Accu-Keyer (QRPP style) clock circuit. This design features low power consumption, necessary when used with battery-powered QRP rigs. Components fit into original pc-board holes. Changing the value of C1 will also vary the speed of the clock.



For QRPP rigs, a switch closure to ground is sometimes required to key the transmitter. The same type of closure is used with cathode-keyed transmitters. To accommodate this requirement, a simple Darlington transistor circuit is used as the output driver. If grid-block keying is used, then the original circuit may be used with a slight change of values. The current requirement during key-down is determined by the 1,000-Ω resistor on the output transistor. This resistor value also determines the maximum current which may be switched by the output stage. With the value shown, the key-down current was 4 mA with a 5-volt supply. The maximum current the stage could switch was about 300 mA. For lower current requirements the 1000-Ω resistor may be increased in value to decrease the key-down current. The 2N4401 transistor shown can handle up to 40 volts during keyup. For higher key-up voltages, a substitute transistor with appropriate higher V_{ceo}

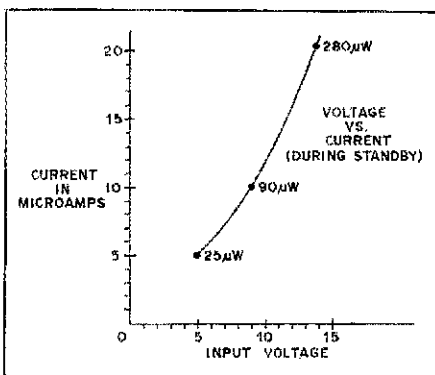

Fig. 2 — Power consumption chart for the Accu-Keyer using CMOS integrated circuits. The standby power is a function of the speed-control setting.

should be used. Most QRPP rigs are operated with under 40 volts and the output transistor is well within limits. All of the transistors shown are non-critical as long as they have reasonable gain and their safe operating voltages and currents are observed.

The CMOS substitutes for the 7400 series of TTL digital circuits are identified by the letter "C" after the 74. Thus, the digital integrated circuits needed are three 74C00s, three 74C74s, and one 74C10. The average price of the 74C00 and 74C10 is under \$1 while the 74C74s are under \$1.50.³ Several of the 74C circuits I originally purchased from surplus outlets proved to be defective over part of their operating voltage range. It is wise to test the devices for correct operation.

In addition to the low power requirement of the 74C series of CMOS is the wide range of supply voltage permissible. The CMOS Accu-Keyer may be operated from a voltage source between 5 and 15 volts. Supply regulation is also noncritical, so large power supply filters are not necessary. As a precautionary action, a 15-V Zener diode should be installed on the board. This will protect the CMOS devices from any transients which might occur. A 9-V transistor radio battery may be used or the voltage may be derived from the QRPP rig. Since the keyer draws such minute current when not being used, the battery should last for months. Power consumption versus battery voltage is shown in Fig. 2.

A sidetone oscillator circuit is shown

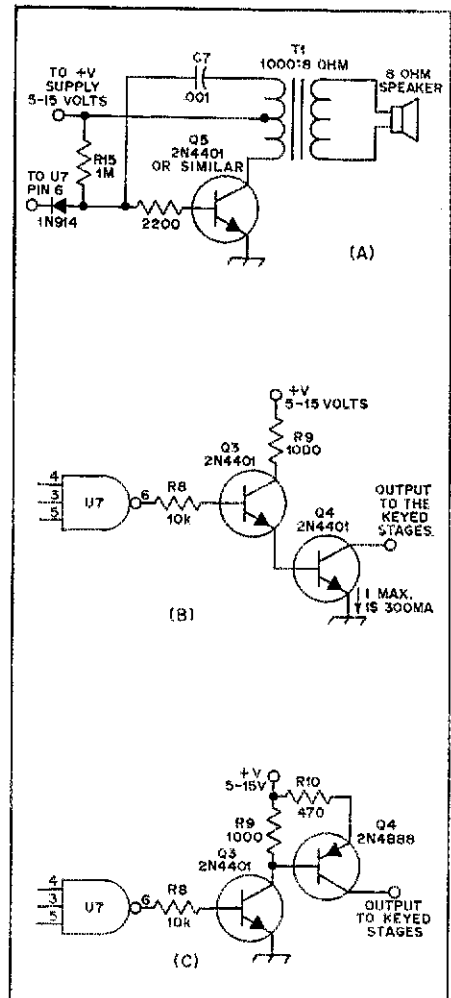

Fig. 3 — At A, schematic diagram of a typical sidetone oscillator. At B and C are two different types of output circuits. Circuit B should be used if the key-up voltage on the keyed terminals of the transmitter are normally positive and require a switch closure to ground. Circuit C is used with transmitters which use a negative voltage to ground for keying, as in grid-block keying.

³ Poly Paks Inc., P. O. Box 942H Lynnfield, MA 01940. Also International Electronics, P. O. Box 1708R, Monterey, CA 93940.

in Fig. 3A.⁴ The oscillator, if needed, will require an additional 1 mA to operate during keying. Since many rigs have their own sidetone oscillator built-in, this circuit may not be needed.

When working with the 74C series of CMOS, it is recommended that a

⁴ Pollock, "COS MOS IC ElectronicKeyer," *Ham Radio*, June, 1974.

grounded-tip soldering iron be used. This is to protect the insulated-gate inputs on the CMOS from being punctured due to high electrostatic fields. It is highly recommended that Molex pins or IC sockets be used. The Molex pins are very inexpensive and will permit the CMOS to be plugged into the circuit board instead of soldered.

I hope this information will be of

interest and help to other amateurs interested in QRPP keyer designs. The Accu-Keyer printed circuit board makes the assembly of this keyer extremely simple and quick. The addition of CMOS to the Accu-Keyer permits it to be competitive with the most expensive Morse senders, and yet the cost is still reasonable. QST

Fig. 4 - Schematic diagram of the Accu-Keyer using 74C00 series CMOS integrated circuits. Four additional 10-kΩ resistors are added to the original printed circuit board for logic pull-ups. Supply voltage may vary from 5 to 15 volts.

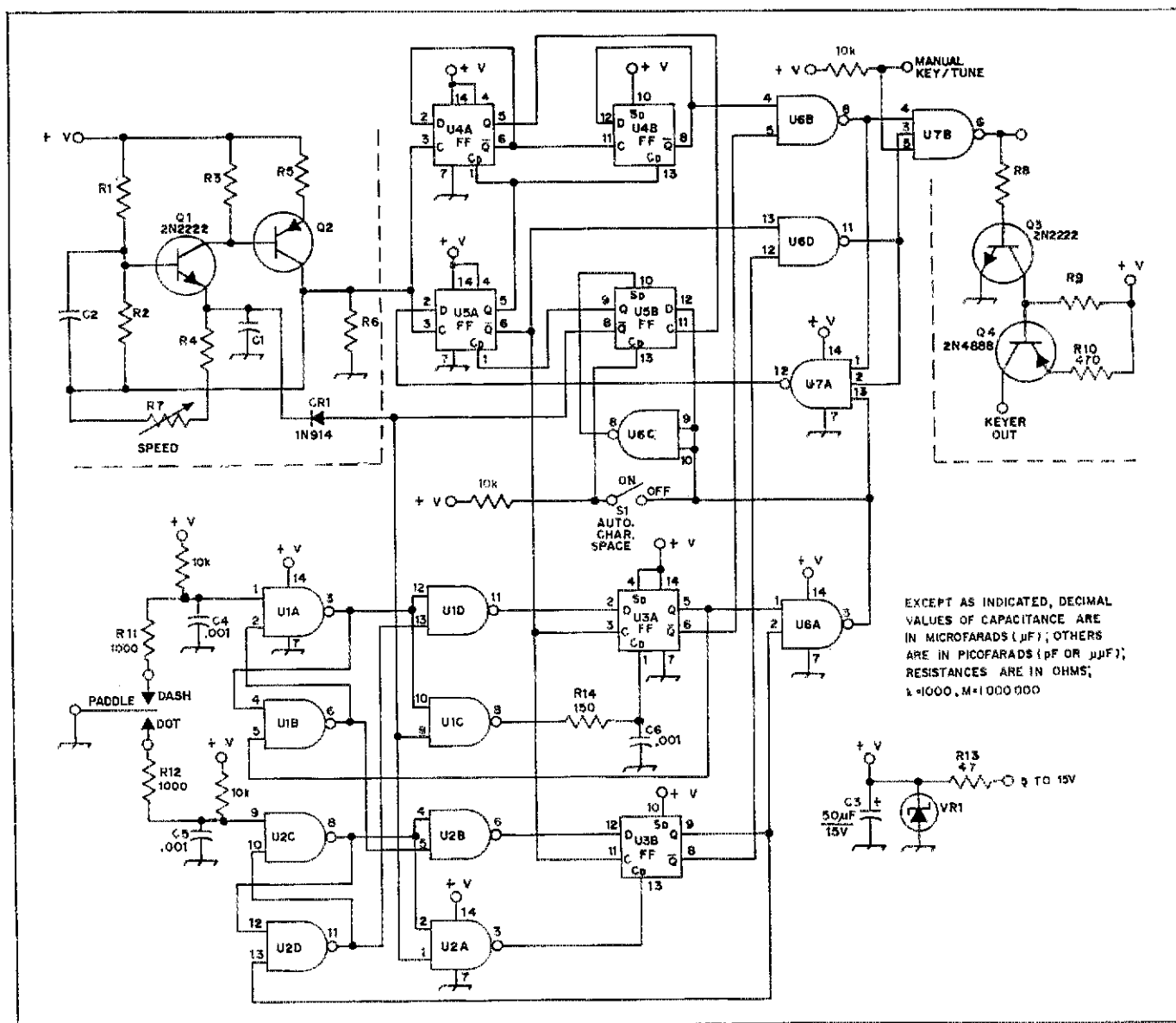

Strays

□ Do you have four months of free time, an extra \$500 and a horse? Then the Dominguez-Escadante Bicentennial Expedition is the place for you. The 1700-mile trip, which will follow the

route taken by two Franciscan missionaries in 1776, needs a radio operator to relay progress reports and requests for supplies and to handle emergency messages. (Is there a Q-signal for "I've just been bitten by a rattlesnake?")

This is a unique opportunity for the hoof-loose and fancy free QRP fan. The trip will transverse some of the most beautiful unspoiled land in the West,

and promises to be an unforgettable experience. With any luck, the radio operator can obtain special-events call signs for the three different call areas in Colorado, Utah and New Mexico.

For further information and application forms, contact the League or Bill Daley, ARBA, Suite 222, 1515 Cleaveland Place, Denver, CO 80202, as soon as possible.