

Software Defined Radio

(SoftRock Lite Receiver &
PowerSDR™ Software)

Web Links

<http://www.kb9yig.com/>

⊕ **Upgraded 20m SoftRock Lite II Receiver
(Assembled, Tested, Warranty)**

\$41.00 each

Check back soon.

The upgraded 20m SoftRock Lite II provides an entry-level SDR receiver with a fixed center frequency of approximately 14.047 MHz. When used with a sound card that can sample at 96 kHz, the band coverage is from below 14.0 MHz to about 14.095 Mhz. This option is assembled, tested and includes a 90-day warranty. This assembled kit also includes a 3' stereo audio cable with 1/8" stereo plug, DC power leads and 6" antenna coax.

<http://support.flex-radio.com/Downloads.aspx?fr=1>

PowerSDR v1.18.3.exe	PowerSDR 1.18.3 Software Installation Program Version: 1.18.3 Date: 9-Sept-2009. IMPORTANT: This Version of PowerSDR requires both .NET Framework 1.1 AND 3.5 to operate properly. NOTICE for FLEX-5000 Users: Firmware version 1.3.0.8 is recommended. NOTICE for FLEX-3000 Users: Firmware version 1.2.5.6 is recommended. It is recommend that both the FLEX-5000 and FLEX-3000 use the FLEX Firewire driver v3.4.2.6300 or higher. You must install the updated Firewire driver before installing the updated firmware. Filesize: 2,711,552 bytes http://support.flex-radio.com/Downloads.aspx?id=294	Software: FlexRadio	5233	9/15/2009
--------------------------------------	--	------------------------	------	-----------

http://www.wb5rvz.com/sdr/sr_lite_ii/

Softrock Lite II Project

[Home](#) [Bill of Materials](#) [Power Supply](#) [Local Oscillator](#) [Divider](#) [Operational Amplifiers](#) [Band Pass Filter](#) [Mixer](#) [External Connections](#) [Comments](#) [Revisions as of //11/2009](#) [WB5RVZ Main Homepage](#)

SoftRock Schematic

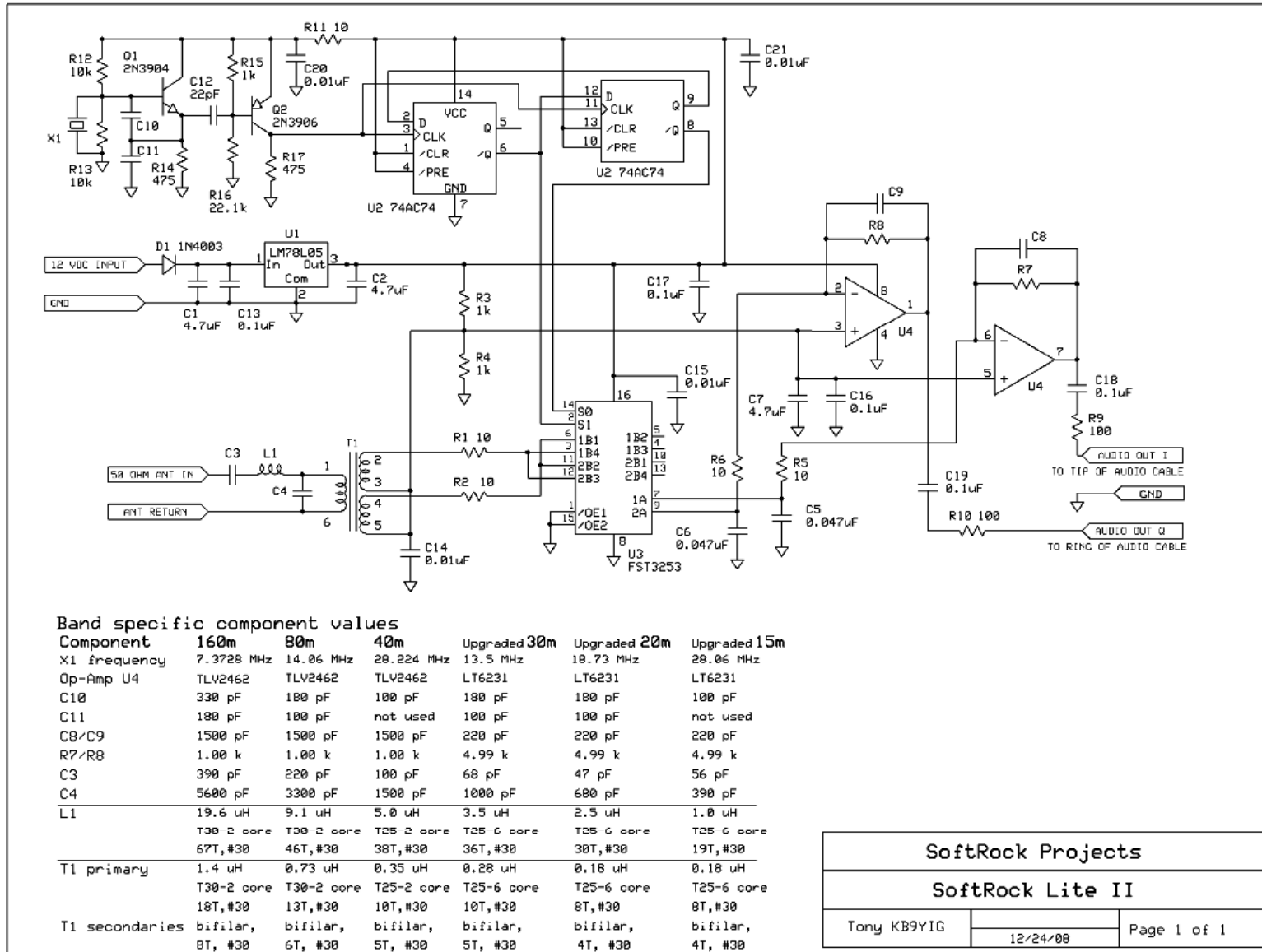

SoftRock Projects

SoftRock Lite II

Tony KB9YIG

12/24/08

Page 1 of 1

PowerSDR Setup

The screenshot displays the PowerSDR software interface. At the top, the title bar reads "FlexRadio Systems™ PowerSDR™ v1.18.2". The main window shows two VFOs: VFO A is set to 14.046 883 MHz with a mode of "20M CW" and a TX indicator; VFO B is set to 7.000 000 MHz with a mode of "40M Extra CW". A spectrum display is visible in the center, showing a signal at 14.046 MHz. On the left, there are controls for AGC-T, Drive, AGC Preamp, SQL, and BCI Rejection. On the right, there are meters for RX1 and TX, showing a signal level of -200 dBm. A yellow callout box with the text "Select Soft Rock 40 Radio Model" has an arrow pointing to the "Soft Rock 40" radio model option in the "PowerSDR Setup" dialog box. The dialog box is open to the "Options" tab, showing various configuration options for the radio model, including SDR-1000 Config and DDS settings.

PowerSDR Setup

General | Audio | Display | DSP | Transmit | PA Settings | Appearance | Keyboard | Ext. Ctrl | CAT Control | Tests

Hardware Config | Options | Calibration | Filters | RX2

Radio Model

- FLEX-5000
- SDR-1000
- Soft Rock 40
- Demo/None

SoftRock Options

Center Freq (MHz): 14.043300

Wizard...

SDR-1000 Config

LPT Address: 378

LPT Delay: 0

USB Adapter

PA Present

XVTR Present

Enable RFE PA TR

DDS

Expert

Receive Only

Reset Database | Import Database... | OK | Cancel | Apply

Baseband 0.0 Hz

The screenshot displays the PowerSDR software interface. A yellow callout box highlights the XTAL Frequency as 14.043300 MHz (Baseband 0.0 Hz). The main display shows a CW signal at 14.043302 MHz with a power level of -65.1 dBm. The RX1 Meter shows a signal level of -108 dBm. The interface includes various control panels for VFO, DSP, and Mode Specific Controls.

XTAL Frequency
14.043300 MHz
(Baseband 0.0 Hz)

VFO B
7.000 000
TX 40M Extra CW

RX1 Meter
Signal: [Signal] Fwd Pwr: [Fwd Pwr]
-108 dBm

Band - HF

160	80	60
40	30	20
17	15	12
10	6	2
VHF+	WVW	GEN

Mode - CWU

LSB	USB	DSB
CWL	CwU	FMN
AM	SAM	SPEC
DIGL	DIGU	DRM

Filter - 750

1.0k	800	750
600	500	400
250	100	50
25	Var 1	Var 2

Mode Specific Controls - CW

CW Speed: 25 Pitch Freq (Hz): 600 VAC

Iambic
 Disable Monitor
 Show TX CW Frequency

Break In: Enabled Delay (ms): 60

System Information
Date/Time: 11/9/2009
LOC: 16:46:57
CPU %: 57.8

Tuning CW Signal

The screenshot displays the FlexRadio Systems PowerSDR v1.18.2 interface. The main display shows a CW signal at 14.054 MHz in AVG Mode. A yellow callout box with the text "CW Signal 14.054 MHz (AVG Mode)" has an arrow pointing to the signal peak on the spectrum display. The interface includes various controls for VFO A and VFO B, a signal meter showing -95 dBm, and a filter set to 750 Hz. The CW mode is set to CWU.

FlexRadio Systems™ PowerSDR™ v1.18.2

Setup Memory Wave Equalizer XVTRs CWX

VFO A
14.054 604
20M CW TX

VFO Sync VFO Lock 7.000000 Save Restore
Tune Step: - 1kHz +

VFO B
7.000 000
TX 40M Extra CW

RX1 Meter TX Meter
Signal Fwd Pwr
-95 dBm

Band - HF
160 80 60
40 30 20
17 15 12
10 6 2
VHF+ WWV GEN

Mode - CWU
LSB USB DSB
CWL **CWU** FMN
AM SAM SPEC
DIGL DIGU DRM

Filter - 750
1.0k 800 **750**
600 500 400
250 100 50
25 Var 1 Var 2
Low 225 High 975
Width: Shift: Res

Display
4.0 2 0 -2 -4 -6 -8 -10 -12 -14 -16 -18 -20
14.052 14.054 14.056 14.058 14.060 14.062
-6519.5Hz -110.7dBm 14.047 484 MHz

Pan: Center Zoom: 0.5x 1x 2x 4x

VFO
SPLT A > B
0 Beat A < B
IF->V A <> B
XIT 0 RIT 0
0 0
CPU %: 43.1

DSP
NR ANF
NB NB2
SR BIN
MultiRX
MultiRX Swap

Display Mode
Panadapter
AVG Peak

Mode Specific Controls - CW
CW Speed: 25 Pitch Freq (Hz): 600 VAC
Iambic
Disable Monitor
Show TX CW Frequency
Break In
 Enabled Delay (ms): 60

MON TUN
MOX
MUT X2TR
Rec Play
AF: 10
AGC-T: 90
Drive: 50
AGC Preamp
Fast High
SQL 130
BCI Rejection
Date/Time
11/9/2009
LOC 16:54:43

Tuning CW Signal

The screenshot displays the FlexRadio Systems PowerSDR v1.18.2 interface. The main display shows a CW signal at 14.050 MHz with a 250 Hz bandwidth. The signal is shown in a waterfall view, and the bandwidth is highlighted in green. The interface includes various controls for VFO A and VFO B, a display of the signal, and a filter section. The filter is set to 250 Hz. The signal strength is -99 dBm. The interface also shows a date/time display (11/9/2009, LOC 17:32:05) and a CPU usage indicator (39.1%).

VFO A
14.050 659
20M CW TX

VFO B
7.000 000
40M Extra CW

Display
14.050 14.051 14.052
-40
-60
-80
-100
-120
-140
047
047
14.050 14.051 14.052 14.
590.2Hz -123.7dBm 14.050 649 MHz

RX1 Meter TX Meter
Signal Fwd Pwr
-99 dBm
1 3 5 7 9 +20 +40 +60

Band - HF
160 80 60
40 30 20
17 15 12
10 6 2
VHF+ WwV GEN

Mode - CWU
LSB USB DSB
CwL CwU FMN
AM SAM SPEC
DIGL DIGU DRM

Filter - 250
1.0k 800 750
600 500 400
250 100 50
25 Var 1 Var 2
Low 475 High 725
Width: Shift: Res

Mode Specific Controls - CW
CW Speed: 25 Pitch Freq (Hz): 600 VAC
Break In
 Enabled Delay (ms): 60
 Disable Monitor
 Show TX CW Frequency

Display Mode
Panafall
AVG Peak

DSP
NR ANF
NB NB2
SR BIN

MultiRX
MultiRX
Audio gain for Sub RX

Stop
MON TUN
MOX
MUT X2TR
Rec Play
AF: 10
AGC-T: 90
Drive: 50
AGC Preamp
Fast High
SQL 130
BCI Rejection
Date/Time
11/9/2009
LOC 17:32:05
CPU %: 39.1

Annotations:
CW Signal
14.050 MHz
Panadapter
Waterfall
(AVG Mode)
250 Hz
Bandwidth